

Packaging Pictures(TTR4.5mic)

Cap (6"strengthened type)



Retainer(2cm thickness)



Paper core width 950mm (roll width:



Safe packaging,with wrapped film & plastic 2 PE layers on each surface



Dehumidification material in each ca



Carton tied tightly,
and between every 2 cartons,
there is one board



Packging pic(if roll width 910mm)

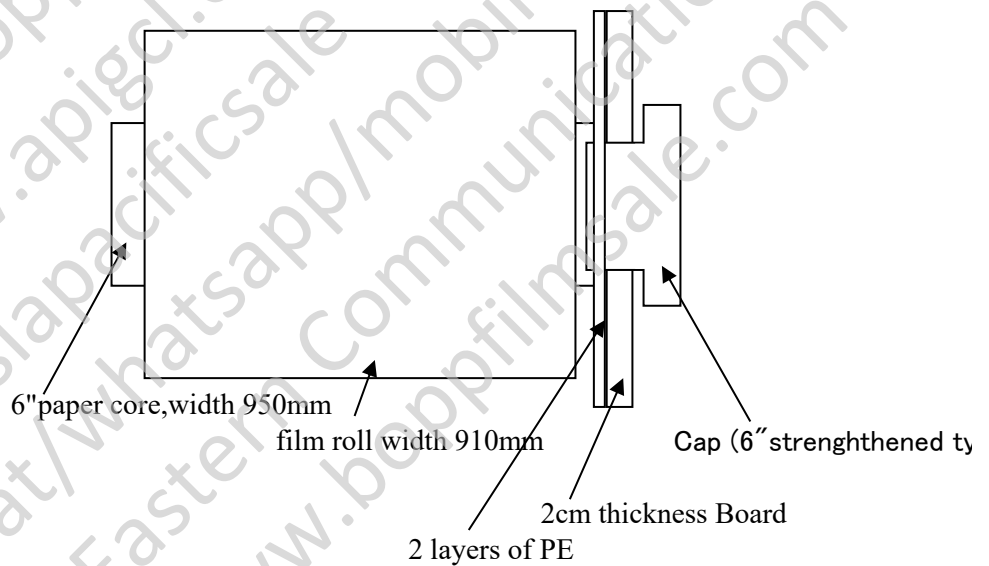

Production plant Pictures(TTR4.5mic)

Lab room



MDO+TDO



Bruckner Machinery, 5800mm width



2 Slitting machines, 5800mm width each



Packaging Pictures(TTR4.5mic)

Cap (6"strengthened type)

Retainer(2cm thickness)

Paper core width 950mm (roll width:910mm)



Safe packaging, with wrapped film & plastic 2 PE layers on each surface

Dehumidification material in each carton



Asia Pacific Industry Group Co., Limited
<http://www.boppfilmsale.com>
<http://www.apigcl.com>
Skype: asiapacificsale
Wechat/whatsapp/mobile: 86-18919654871
Anhui Eastern Communication
<http://www.boppfilmsale.com>

Carton tied tightly,
and between every 2 cartons,
there is one board



Packging pic(if roll width 910mm)

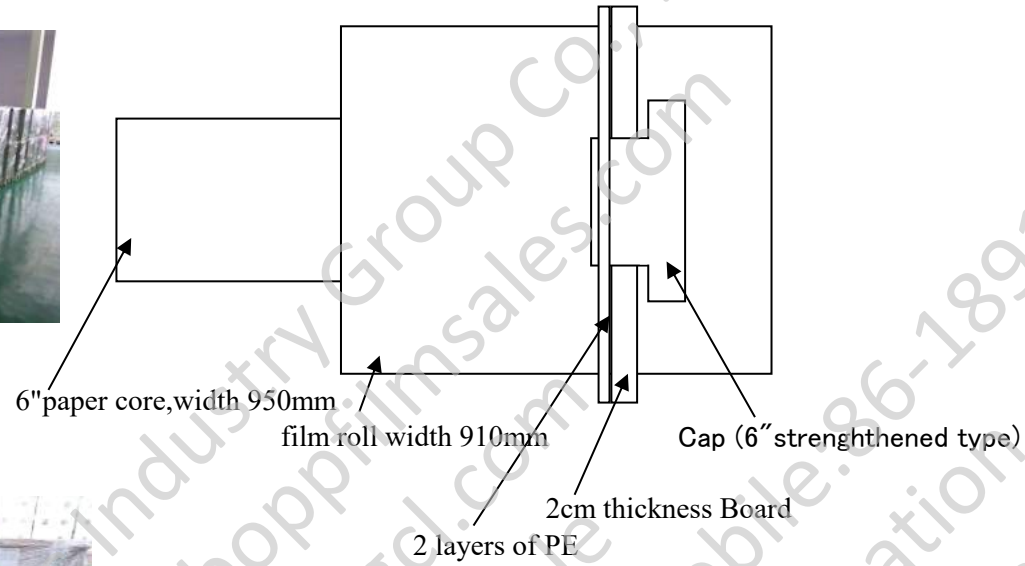

Asia Pacific Industry Group Co., Limited
<http://www.boppfilmsales.com>
<http://www.apiglobal.com>
Skype: asiapacificsales
Wechat/whatsapp/mobile: 86-18919654871
Anhui Eastern Communication
<http://www.boppfilmsale.com>